

CLAMPER

S·SH

シンプルな標準タイプ。T溝手動スライド式。
Basic standard type.
Manual sliding and inserting T slot type.

仕様 Specification

型式 Type	S-1T	S-2T	S-4T	S-6T	S-10T	S-16T
耐圧 Proof pressure MPa kgf/cm ²	27.0 275					
最高使用圧力 Max. working pressure MPa kgf/cm ²	18.1 185					
クランプ力 Clamping force kN ton	9.8 1	19.6 2	39.2 4	58.8 6	98.0 10	156.9 16
必要油量 Required oil volume ml	4.6	9.1	18.7	27.8	47.6	75
使用温度範囲 Ambient temperatures range ℃	0~60					
使用油 Recommended fluid	一般油圧作動油(ISO VG32) General hydraulic fluid					
重量 Weight (J=80時) kg (at J=80)	0.8	1.5	2.3	3.6	6.5	13.0

型式 Type	SH-1T	SH-2T	SH-4T	SH-6T	SH-10T	SH-16T
耐圧 Proof pressure MPa kgf/cm ²	36.7 375					
最高使用圧力 Max. working pressure MPa kgf/cm ²	24.5 250					
クランプ力 Clamping force kN ton	9.8 1	19.6 2	39.2 4	58.8 6	98.0 10	156.9 16
必要油量 Required oil volume ml	2.0	6.6	13.0	19.0	33.0	54.0
重量 Weight (J=80時) kg (at J=80)	0.5	1.3	1.8	2.9	5.2	10.3

型式表示 Type designation

S ① — ② T — ③ — ④ — ⑤

- ①最高使用圧力 Max. working pressure 18.1MPa ; 無記号 No symbol
24.5MPa ; H
- ②クランプ力 Clamping force (ton)
- ③締付高さ Clamping height J(mm)
- ④ロッド形状番号 Shape No of rod
(メーカーサイドで決定します。)
(To be determined by manufacturer)
- ⑤標準仕様 Standard 無記号 No symbol
特殊仕様 Option Z(n)

外形寸法図 Shapes and dimensions

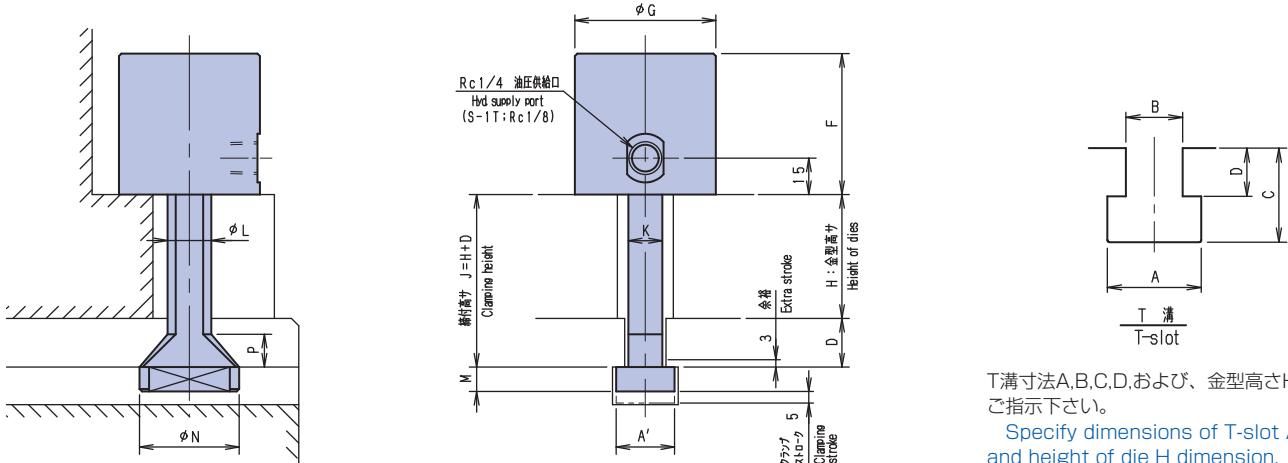

T溝寸法A,B,C,Dおよび、金型高さH寸法をご指示下さい。
Specify dimensions of T-slot A,B,C,D, and height of die H dimension.

型式 Type	J 標準範囲 Standard range	F	G	K (MIN.)	L	M (MIN.)	N	P
S- 1T	~ 70	52	44	9	15	6	30	9
S- 2T	30~ 80	58	58	12	18	7	41	13.5
S- 4T	36~ 90	61	73	17	25	9	59	19
S- 6T	36~100	67	88	20	29	13	64	19
S-10T	45~110	77	112	25	39	15	79	21.5
S-16T	50~120	87	146	31	49	20	94	21.5

型式 Type	J 標準範囲 Standard range	F	G	K (MIN.)	L	M (MIN.)	N	P
SH- 1T	~ 70	41	38	9	15	6	30	9
SH- 2T	30~ 80	58	51	12	18	7	41	13.5
SH- 4T	36~ 90	61	62	17	25	9	59	19
SH- 6T	36~100	67	78	20	29	13	64	19
SH-10T	45~110	76	98	25	39	15	79	21.5
SH-16T	50~120	84	127	31	49	20	94	21.5